

规 格 书

SPECIFICATION

CUSTOMER NAME 客户名称: _____

CUSTOMER NO. 客户编号: _____



SERIES 系 列: TACT SWITCH

MODEL NO. 型 号: TP2030-60-2-A-180gf

DRAWING NO. 图 形 号: F2A-11

If specification of this product meets your request, please confirm all the items of it and return to us with signature and stamp, it will be basis of our production and record. Thanks your cooperation in advance!

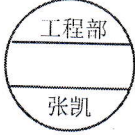
若此产品规格符合贵公司要求, 敬请确认规格书内所有项目并签名和盖章后回传给我司, 以作我司产品制作之依据和存档之用, 多谢合作!

EXAMINE & APPROVAL 审批			
APPROVE 接受		NOT APPROVE 不接受	
SIGNATURE 签署	STAMP 盖章	DATE 日期	SIGNATURE 签署
DATE 日期	STAMP 盖章	DATE 日期	SIGNATURE 签署
PREPARED BY.制表人	CHECKED BY.校对	APPROVED BY.审核	NO.
			

SYMB	REVISION	DATE	APPD.	DATE	APVD.	VERSION: 3	F2A-11-1/1
	A					MODE	Tactile Feedback
						TIMING	
						LINE(S)	CIRCUIT
						1	1P1T
							STROKE
							0.15

Without any banned substance! Compliance with RoHS!

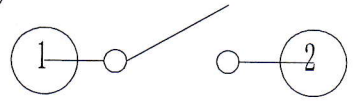
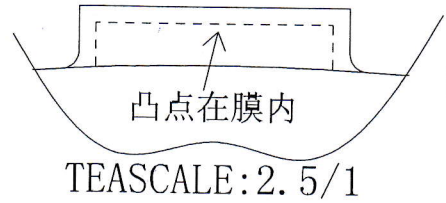
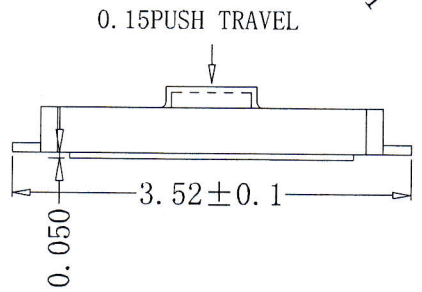
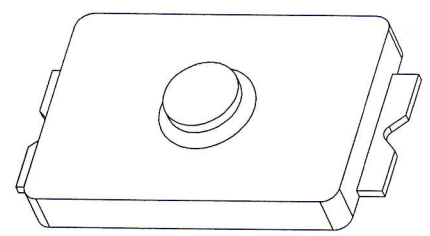
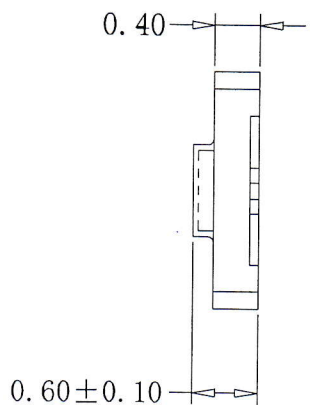
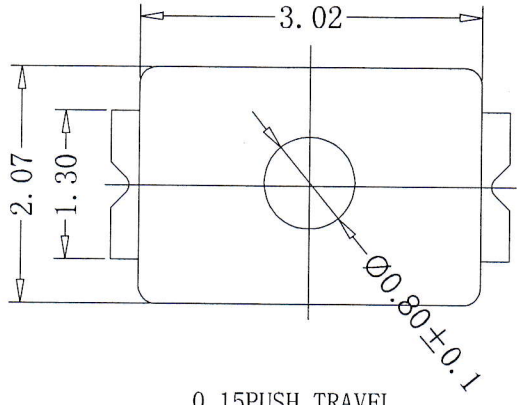

CIRCUIT DIAGRAM

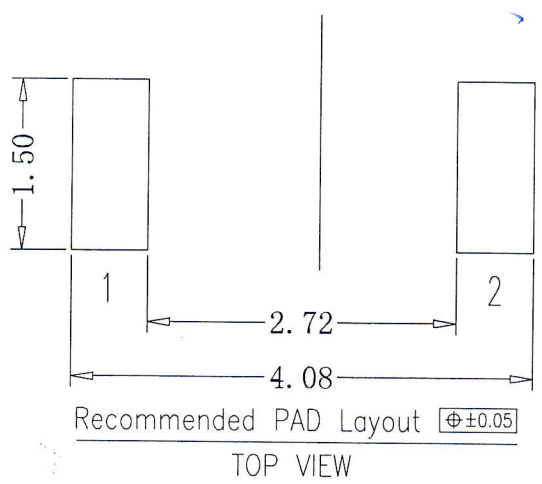

TOP VIEW

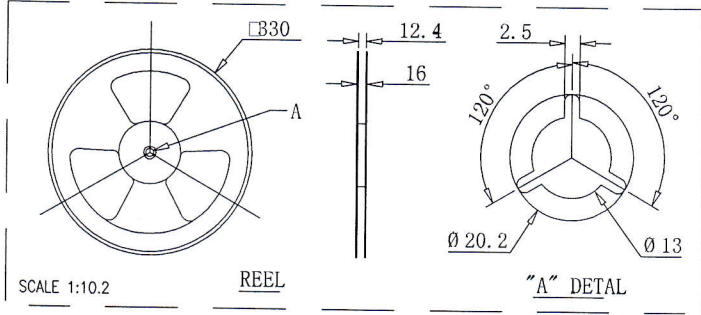

SCALE 1:10.2 REEL

"A" DETAIL

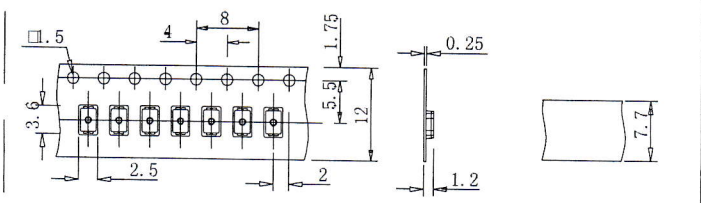

SCALE 1.2:1 CARRIER TAPE

COVER TAPE

PACKING DETAIL

<QTY: 10000PCS/REEL>

TYPE	TACT SWITCH		UNIT	mm	9			
SERIES	TP2030-60-2		SCALE	14:1	8			
PART NO.	TP2030-60-2		DATE	14/12/30	7			
SPEC. NO.	TP2030-60-2-A		PAGE	1/6	6			
DRAWN	CHECKED	APVD.	TOLERANCE		5	TAPE	PI 0.125mm	1 YELLOW
			ANGLE	±3°	4	TERMINAL 1,2	PBS	2 Ag PLATED
			UP TO 1	±0.1	3	STEM	PI	1 BLACK
			ABOVE 1 ~ 5	±0.2	2	CONTACT	SUS	2 Ag CLAD
			ABOVE 5 ~ 50	±0.3	1	CASE	LCP	1 BLACK
						MATERIAL	QTY.	FINISHING

由 Autodesk 教育版产品制作

由 Autodesk 教育版产品制作

BEST TECHNOLOGY CO., LTD		文件编号 FILE NO.	YJ-CRS-005	页码 PAGE	2/8
		发布日期 DATE OF ISSUE	2015 年 05 月 23 日		
PRODUCT SPECIFICATION 产品承认书		文件版本 EDITION	第 A 版第 0 次修订		
TACT SWITCH 轻触开关	TP2030-60-2-A	产品编码 PART NO	TP2030-60-2-A-180gf		

<p>1. General Characteristics 一般特性:</p> <p>适用范围:</p> <p>1.1、This specification is applied to the requirements for TACTILE SWITCH (MECHANICAL CONTACT) 此规格书适用于机械式轻触开关的相关要求</p> <p>1.2 Operating Temperature Range: -30°C to 85°C 使用温度范围: -30°C to 85°C</p> <p>1.3 Operating Relative Humidity: ≤85%RH 相对湿度: ≤85%RH</p> <p>1.4 Test Conditions: Unless otherwise specified, the atmospheric conditions for making measurements and tests are as follows: 实验条件: 若没有特别说明, 则试验大气条件如下: Ambient Temperature: 5~35°C, Relative Humidity: 45~85% 环境温度: 5~35°C, 相对湿度: 45~85% Air Pressure: 86~106Kpa (860~1060mbar) 大气压力: 86~106Kpa (860~1060mbar)</p>			
<p>2. Appearance, Structure and Dimensions 外观, 结构及尺寸:</p> <p>2.1 Appearance: The switch shall have good finishing, and no rust, crack or plating defects. 外观: 产品外观良好, 无锈蚀、裂纹和镀层缺陷。</p> <p>2.2 Structure & Dimensions: Refer to individual product drawing. 结构及尺寸: 参见产品图纸</p> <p>2.3 Markings: Refer to individual product drawing. 标识: 参见产品图纸。</p>			
3. Ratings 额定负荷		DC12V 50mA	
4. Electrical Characteristics 电气特性			
No.	Item 项目	Criteria 标准	Test Method 实验方法
4.1	Contact Resistance 接触电阻	100mΩ Max.	在以 5V 10mA 的直流电源或不低于 1KHz 的交流电源的电路中, 以一个等于 2 倍按力的静负荷施加于手柄中心 Applying a static load of 2 times operating force to the center of the stem, measurements shall be made by 5V DC 10mA or more than 1KHZ AC small-current contact resistance meter.
4.2	Resistance Insulation 绝缘电阻	100MΩ Min.	Measurement shall be made following application of 100V DC potential, across terminals, and across terminals and cover, for one minute. 在端子之间施加 DC 100V /1min 的条件下, 测量端子之间底座、盖板的电阻值。
4.3	Dielectric Voltage 抗电强度	No dielectric breakdown shall occur. 无击穿现象发生。	250VAC (50~60Hz, cut-off current 2mA) is applied between non-connected terminals and between terminals and the metal frame for 60 ±5s. 在相互绝缘的所有接线端子之间 250V (50-60Hz) 交流电, 各接线端子与外壳或非载流金属零件之间加载 250V (50-60Hz) 交流电, 持续时间 60 ±5S。

BEST TECHNOLOGY CO., LTD		文件编号 FILE NO.	YJ-CRS-005	页码 PAGE	3/8
		发布日期 DATE OF ISSUE	2015 年 05 月 23 日		
PRODUCT SPECIFICATION 产品承认书		文件版本 EDITION	第 A 版第 0 次修订		
TACT SWITCH 轻触开关	TP2030-60-2-A	产品编码 PART NO	TP2030-60-2-A-180gf		

5. Mechanical Characteristics 机械特性

No.	Item 项目	Criteria 标准	Test Method 实验方法
5.1	Operating Force 操作力	180±40gf	Apply a static load on the midpoint of the actuator (or tip of the shaft) to supply a pressure vertically from its free position to operating position. 在操作元件末端沿操作方向均匀施加静载荷, 使操作元件转换到动作位置。
5.2	Return Force 回弹力	40 gf Min	The value to which the force in the actuator midpoint (or tip of the shaft) must be reduced to allow the contact to the normal position. 在操作元件末端沿操作方向均匀减少静载荷, 使操作元件从动作位置转换到自由位置。
5.3	Operation Position 操作位置	0.15±0.05mm	开关垂直于操作方向放置, 以一个等于 2 倍按力的静负荷施加在开关驱动件顶端中心, 测量顶端移动的距离。 Placing the switch such that the direction of switch operation is vertical and then applying static load of 2times operating force to the center of the stem; the travel distance for the switch to come to a stop shall be measured.
5.5	Terminal Strength 端子强度	Shall be free from terminal looseness, damage and insulator breakage. No functional defective occur 端子无松动, 损坏及绝缘层的破裂。无功能性不良	A static load of 0.5N shall be applied to the tip of terminal in a desired direction for 10 ± 1s. The test shall be done once per terminal. 以 0.5N 作用力沿轴向逐渐施加于接线端末端 10±1s(作用力方向为离开开关向外指向), 每个接线端子测量一次。
5.6	Vibration Proof 振动	After test, Contact resistance: 200 mΩ Max. I No functional defective occur No abnormalities shall be recognized in appearance and construction. 实验后: 接触电阻: 200 mΩ Max. 无功能性不良。 表面及结构无明显变形	Switch shall be secured to a testing machine by a normal mounting device and method. Switch shall be measured after following test. (1) Vibration frequency range 10~55 Hz (2) Total amplitude 1.5mm (3) Sweep ratio: 10~55~10Hz Approx. 1 min (4) Method of changing the sweep vibration frequency: logarithmic or linear (5) Direction of vibration: Three perpendicular directions including actuating direction. (6) Duration: 2 hours (6 hours in total) 开关采用常规的安装方法牢固地安装在试验设备上, 并在下述参数条件下进行试验: (1) 振频 10-55Hz (2) 振幅 1.5mm (3) 振动变化速率: 10-55-10Hz 大约 1 分钟 (4) 变频方法: 对数或线性型式 (5) 振动方向: 三个相互垂直的方向, 其中一个方向应是促动元件运动的方向。 (6) 时间: 每个方向 2 小时 (共 6 小时)。

BEST TECHNOLOGY CO., LTD		文件编号 FILE NO.	YJ-CRS-005	页码 PAGE	4/8
		发布日期 DATE OF ISSUE	2015 年 05 月 23 日		
PRODUCT SPECIFICATION 产品承认书		文件版本 EDITION	第 A 版第 0 次修订		
TACT SWITCH 轻触开关	TP2030-60-2-A	产品编码 PART NO	TP2030-60-2-A-180gf		

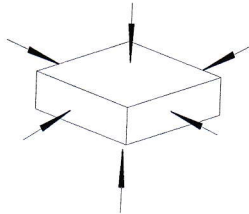
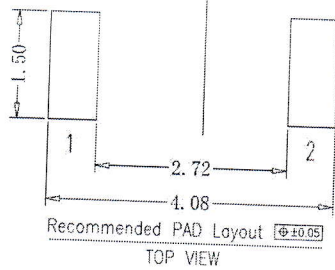
No.	Item 项目	Criteria 标准	Test Method 实验方法
5.7	Mechanical Shock 冲击	<p>After test, Contactresistance:200mΩMax. No functional defective occur Shall be free from mechanical abnormalities.</p> <p>实验后: 接触电阻: 200 mΩMax. 无功能性不良。 表面无变形且操作无异常。</p>	<p>Switch shall be measured after following test:</p> <p>(1) Mounting Method: Normal (2) Acceleration: 490m/s² (50G) (3) Duration: 11ms (4) Test Direction: 6 directions</p>  <p>(5)Number of shocks: 3 times per direction (18 times in total) 试件在下述参数条件下进行试验:</p> <p>(1) 安装方法: 常规方法 (2) 加速度: 490m/ s² (50G) (3) 时间: 11ms (4) 实验方向: 图示 6 方向 (5) 冲击次数: 每个方向 3 次 (总共 18 次)</p>
5.8	Solder Ability 可焊性	<p>More than 90% of immersed part shall be covered with solder. 超过 90% 的浸锡面积被焊料所覆盖。</p> <p>建议钢网尺寸如下图所示:</p>  <p>Recommended PAD Layout ± 0.05 TOP VIEW</p>	<p>Switch shall be tested according to the following request:</p> <p>(1) Equipment: Auto-Dip Chamber (2) Solder: Normal (3) Flux: Rosin Flux having a nominal composition of 25% solids by mass of water white rosin in methyl alcohol solution. (4) Soldering Temperature: 255 ± 5°C (5) stencil thickness: 0.1mm, The thickness of the solder paste: ≤0.12mm (6) Immersion Depth: Immersion depth shall be at copper plating portion of PCB after mounting. (7)Prohibit contact items: alcohol, gasoline, Isophorone 开关在下述参数条件下进行试验:</p> <p>(1) 设备: 自动焊接机 (2) 焊料: 常规 (3) 焊剂: 焊剂, 质量百分比为 25% 松香, 75% 甲醇的无色透明溶液。 (4) 焊接温度: 255 ± 5°C (5) 建议钢网厚度为 0.1mm, 所刷锡膏厚度 ≤0.12mm。 (6) 浸渍深度: 接线端应浸到开关根部处。 (7) 禁止使用酒精, 汽油, 慢干水 (异佛尔酮) 等化学物品接触开关。</p>

BEST TECHNOLOGY CO., LTD		文件编号 FILE NO.	YJ-CRS-005	页码 PEGE	5/8
		发布日期 DATE OF ISSUE	2015 年 05 月 23 日		
PRODUCT SPECIFICATION 产品承认书		文件版本 EDITION	第 A 版第 0 次修订		
TACT SWITCH 轻触开关	TP2030-60-2-A	产品编码 PART NO	TP2030-60-2-A-180gf		

No.	Item 项目	Criteria 标准	Test Method 实验方法
5.9	Solder Heat Resistance 耐焊接热	No abnormalities shall be observed in appearance and operation. No functional defective occur 无外观及功能损坏。 无功能性不良。	<p>Please practice according to below condition:</p> <p>(1) Preheat :150°C 90-120s (2) Soldering heat : 260°C Max 10S. (3) Immersion depth: Up to the surface of the board 焊接方法: (1) 预热: 150°C 90-120s (2) 最高焊接温度: 260°C Max 10S. (3) 浸渍深度: PCB 表面)</p> <p>回流焊曲线图</p>
5.10	Resistance to Flux 抗焊剂能力	Flux shall not be risen up to contact. The switch shall be free from abnormalities in operation. 焊剂不得上升进入开关内部, 影响接触转换。 试件在操作过程中不应发生变形。	<p>switch shall be tested according to the following request:</p> <p>(1)switch Equipment: Auto-Dip Chamber (2)Solder: Normal (3)Flux: Rosin Flux having a nominal composition of 25% solids by mass of water white rosin in methyl alcohol solution. (4)Soldering Temperature: 260 ± 5°C (5)Immersing Time: 3 ± 1s (6)Immersion Depth: Immersion depth shall be at copper plating portion of PCB after mounting. (Thickness of PCB) 开关在下述参数条件下进行试验: (1) 设备: 自动焊接机 (2) 焊料: 常规 (3) 焊剂: 焊剂, 质量百分比为 25%松香, 75%甲醇的无色透明溶液。 (4) 焊接温度: 260 ± 5°C (5) 浸渍时间: 3 ± 1s (6) 浸渍深度: 接线端应浸到离开关根部处。</p>

BEST TECHNOLOGY CO., LTD		文件编号 FILE NO.	YJ-CRS-005	页码 PEGE	6/8
		发布日期 DATE OF ISSUE	2015 年 05 月 23 日		
PRODUCT SPECIFICATION 产品承认书		文件版本 EDITION	第 A 版第 0 次修订		
TACT SWITCH 轻触开关	TP2030-60-2-A	产品编码 PART NO	TP2030-60-2-A-180gf		

6. Durability characteristics

No.	Item 项目	Criteria 标准	Test Method 实验方法
6.1	Mechanical Life 机械寿命	After test, Contactresistance:500mΩ Max. Insulation resistance: 100MΩ Min. Tolerance of operating force Disintegration shall be within 30% of specified value No functional defective occur The switch shall be free from abnormalities in appearance construction.	300,000 cycles of operation shall be performed continuously at a rate of 60 cycles per minute without load. 在加载 2 倍按力负载条件下, 行程高度在 10mm, 速度为 60 次/分, 在寿命试验设备上连续转换 300,000 次。
6.2	Electronics Life 电气寿命	实验后: 接触电阻: 500mΩ Max. 绝缘电阻: 100MΩ Min. 操作力衰变应在±30%以内。 无功能性不良。 开关外观及结构应无损坏。	300,000 cycles of operation shall be performed continuously at a rate of 60 cycles per minute with load as follow DC6V 50mA 在加载 2 倍按力负载的条件下, 行程高度在 10mm, 速度为 60 次/分, 在寿命试验设备上连续转换 300,000 次。 DC6V 50mA

7. Weather Proof Characteristics 耐候性能:

No.	Item 项目	Criteria 标准	Test Method 实验方法
7.1	Cold Proof 低温	After test, Contactresistance:200mΩ Max. Insulation resistance: 100MΩ Min. No functional defective occur The switch shall be free from abnormalities in appearance &construction.	After testing at $-20 \pm 2^{\circ}\text{C}$ for 48 hours, the switch shall be allowed to stand under normal temperature and humidity conditions for 1 hour, and measurement shall be made within 1 hour after that. Water drops shall be eliminated. 试件在 $-20 \pm 2^{\circ}\text{C}$ 的温控箱内保持 48 小时, 然后在正 常温度和湿度下恢复 1 小时, 并在此后 1 小时内对 试品进行测量, 水滴应消失。
7.2	Hot Proof 高温	实验后: 接触电阻: 200mΩ Max. 绝缘电阻: 100MΩ Min. 无功能性不良。 开关外观及结构应无损坏。	After testing at $70 \pm 2^{\circ}\text{C}$ for 48 hours, the switch shall be allowed to stand under normal temperature and humidity conditions for 1 hour, and measurement shall be made within 1 hour after that. 试件在 $70 \pm 2^{\circ}\text{C}$ 的温控箱内保持 48 小时, 然后在正 常温度和湿度下恢复 1 小时, 并在此后 1 小时内对 试品进行测量, 水滴应消失。
7.3	Moisture Resistance 恒定湿热		After testing at $40 \pm 2^{\circ}\text{C}$, 90~95% RH for 48 hours, the switch shall be allowed to stand under normal temperature and humidity conditions for 1 hour, and measurement shall be made within 1 hour after that. Water drops shall be eliminated. 试件在 $40 \pm 2^{\circ}\text{C}$, 90-95%RH 的温控箱内保持 48 小 时, 然后在正常温度和湿度下恢复 1 小时, 并在此 后 1 小时内对试品进行测量, 水滴应消失。

BEST TECHNOLOGY CO., LTD		文件编号 FILE NO.	YJ-CRS-005	页码 PAGE	7/8
		发布日期 DATE OF ISSUE	2015 年 05 月 23 日		
PRODUCT SPECIFICATION 产品承认书		文件版本 EDITION	第 A 版第 0 次修订		
TACT SWITCH 轻触开关	TP2030-60-2-A	产品编码 PART NO	TP2030-60-2-A-180gf		

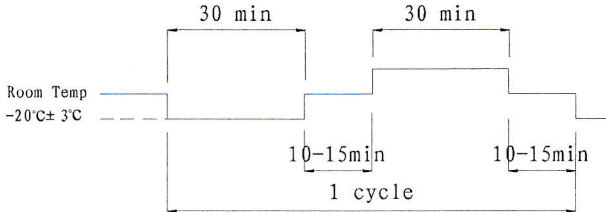
7. Durability characteristics			
No.	Item 项目	Criteria 标准	Test Method 实验方法
7.4	Temperature Cycling 温度转换	After test, Contact resistance: 200mΩ Max. Insulation resistance: 100MΩ Min. No functional defective occur The switch shall be free from abnormalities in appearance & construction. 实验后: 接触电阻: 200mΩ Max. 绝缘电阻: 100MΩ Min. 无功能性不良。 开关外观及结构应无损坏。	After 5 cycles of following conditions, the switch shall be allowed to stand under normal temperature and humidity conditions for 1 hour, and measurement shall be made within 1 hour after that. Water drops shall be eliminated. 试件按下述实验条件试验 5 次, 然后在正常温度和湿度下恢复 1 小时, 并在此后 1 小时内对试品进行测量, 水滴应消失 
7.5	Salt Mist 盐雾实验	No remarkable corrosion shall be recognized in metal part. 在金属件上没有影响开关性能的斑点	The switch shall be checked after following test: (1) Temperature: 35±2°C (2) Salt Solution: 3±1% (Solids by mass) (3) Duration: No action environment 72±1 hour After test, salt deposit shall be removed by running water. 试件在下述实验后测量: (1) 温度: 35±2°C (2) 盐溶液浓度: 3±1% (质量百分比) (3) 时间: 无动作环境下 72±1 小时 实验后的盐沉积物用水冲掉。

BEST TECHNOLOGY CO., LTD		文件编号 FILE NO.	YJ-CRS-005	页码 PAGE	8/8
		发布日期 DATE OF ISSUE	2015 年 05 月 23 日		
PRODUCT SPECIFICATION 产品承认书		文件版本 EDITION	第 A 版第 0 次修订		
TACT SWITCH 轻触开关	TP2030-60-2-A	产品编码 PART NO	TP2030-60-2-A-180gf		

8. Other		
No.	Item 项目	Criteria 标准
8.1	Storage Condition 保存条件	<p>(1)Storage Environment -20 to 50 °C , 20 to 85%RH.(Storage in high temperature and high humidity shall be avoided.)</p> <p>(2)Storage Period Maximum of 3 months after shipment or six months in a plast bag (vinyl) that is not opened.</p> <p>(1)保存环境 温度: -20 -50 °C, 相对湿度 20-85%(应当避免高温高湿环境)。</p> <p>(2)保存期 出货后拆开包装最多保存三个月 (拆开包装后尽量使用我司包装封口保存或者真空包装); 在未打开的塑料包装袋 (乙烯基) 内可保存六个月。</p>